

13.2V Input, 3A Step-Down Converter

General Description

The AAT1161 is an 800kHz high efficiency step down DC-DC converter with wide input voltage range. With 4.0V to 13.2V input rating, the AAT1161 is the perfect choice for 2-cell Li+ battery powered devices and mid power range regulated 12V powered applications. The internal power switch is capable of delivering up to 3A load current.

The AAT1161 is a highly integrated device in order to simplify system level design for the users. It is a non-synchronous converter that is used with an external Schottky diode rectifier for low-cost applications. Minimum external components are required for the converter. All the control circuits are integrated in the IC.

The AAT1161 optimizes efficiency throughout the entire load range. It operates in a combination PWM/Light Load mode for improved light-load efficiency. It can also operate in a forced Pulse Width Modulation (PWM) mode for easy control of the switching noise as well as faster transient response. The high switching frequency allows the use of small external components. The low current shutdown feature disconnects the load from V_{IN} and drops shutdown current to less than 1 μ A.

The AAT1161 is available in a Pb-free, space-saving, thermally-enhanced 14-pin TDFN33 package and is rated over an operating temperature range of -40°C to +85°C.

Features

- Input Voltage Range: 4.0V to 13.2V
- Up to 3A Load Current
- Fixed or Adjustable Output:
 - Output Voltage: 0.6V to V_{IN}
- Less than 1 μ A Shutdown Current
- Up to 95% Efficiency
- Integrated High-Side Power Switch
- External Schottky Rectifier
- 800kHz Switching Frequency
- Soft Start Function
- Short-Circuit and Over-Temperature Protection
- Minimum External Components
- Tiny 14-pin 3x3mm TDFN Package
- Temperature Range: -40°C to +85°C

Applications

- Digital Camcorders
- Industrial Applications
- Portable DVD Players
- Rack Mounted Systems
- Set Top Boxes

Typical Application

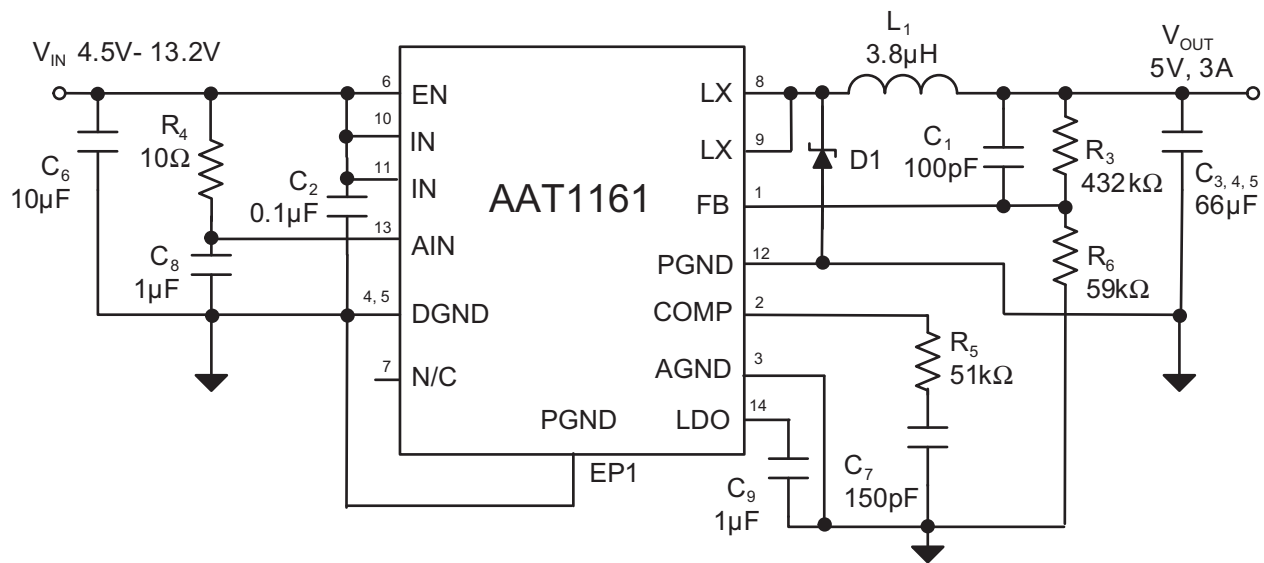

1.3.2V Input, 3A Step-Down Converter

Pin Descriptions

Pin #	Symbol	Function
1	FB	Output voltage feedback input. FB senses the output voltage for regulation control. For fixed output versions, connect FB to the output voltage. For adjustable versions, drive FB from the output voltage through a resistive voltage divider. The FB regulation threshold is 0.6V.
2	COMP	Control compensation node. In most configurations external compensation is not required. If external compensation is required, connect a series RC network from COMP to AGND. See Compensation section.
3	AGND	Analog signal ground. Used for the Compensation, LDO bypass and feedback divider ground. Connect AGND to DGND/PGND at a single point as close to the IC as possible or directly under the package exposed thermal pad (EP).
4, 5	DGND	Digital/Power Ground. Used for the input and enable ground. Connect DGND to AGND/PGND at a single point as close to the IC as possible or directly under the package exposed thermal pad (EP).
6	EN	Active high enable input. Drive EN high to turn on the AAT1161; drive it low to turn it off. For automatic startup, connect EN to IN through a 4.7kΩ resistor. EN must be biased high, biased low, or driven to a logic level by an external source. Do not let the EN pin float when the device is powered.
7	N/C	No Connect. Leave floating; do not connect anything to this pin.
8, 9	LX	Power switching node. LX is the drain of the internal P-channel switch. Connect the external rectifier from LX to PGND and the external LC output filter from LX to the load.
10, 11	IN	Power source input. Connect IN to the input power source. Bypass IN to DGND with a 10μF or greater capacitor. Connect both IN pins together as close to the IC as possible. An additional 100nF ceramic capacitor should also be connected between the two IN pins and DGND.
12, EP	PGND	Power Ground. The exposed thermal pad (EP) should be connected to board ground plane and pins 3, 4, 5 and 12 directly under the package. The ground plane should include a large exposed copper pad under the package for thermal dissipation (see package outline).
13	AIN	Internal analog bias input. AIN supplies internal power to the AAT1161. Connect AIN to the input source voltage and bypass to AGND with a 0.1μF or greater capacitor. For additional noise rejection, connect to the input power source through a 10Ω or lower value resistor.
14	LDO	Internal LDO bypass node. The output voltage of the internal LDO is bypassed at LDO. The internal circuitry of the AAT1161 is powered from LDO. Do not draw external power from LDO. Bypass LDO to AGND with a 1μF or greater capacitor.

Pin Configuration

**TDFN33-14
(Top View)**

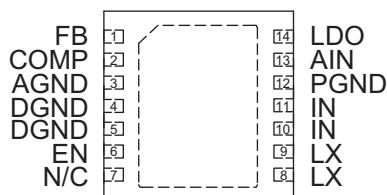

13.2V Input, 3A Step-Down Converter**Absolute Maximum Ratings¹**

Symbol	Description	Value	Units
V_{IN}, V_{AIN}	Input Voltage	-0.3 to 14	V
V_{LX}	LX to GND Voltage	-0.3 to $V_{IN} + 0.3$	V
V_{FB}	FB to GND Voltage	-0.3 to $V_{IN} + 0.3$	V
V_{EN}	EN to GND Voltage	-0.3 to $V_{IN} + 0.3$	V
T_J	Operating Junction Temperature Range	-40 to 150	°C

Thermal Information²

Symbol	Description	Value	Units
P_D	Maximum Power Dissipation ³	2.0	W
θ_{JA}	Thermal Resistance	50	°C/W

1. Stresses above those listed in Absolute Maximum Ratings may cause permanent damage to the device. Functional operation at conditions other than the operating conditions specified is not implied. Only one Absolute Maximum Rating should be applied at any one time.

2. Mounted on an FR4 board.

3. Derate 20mW/°C above 25°C.

13.2V Input, 3A Step-Down Converter

Electrical Characteristics

4.0V < V_{IN} < 13.2V. C_{IN} = 22μF, C_{OUT} = 66μF; L = 2.2μH or 3.8μH, T_A = -40 to +85°C unless otherwise noted. Typical values are at T_A = 25°C.

Symbol	Description	Conditions	Min	Typ	Max	Units
V _{IN}	Input Voltage Range		4.0		13.2	V
V _{UVLO}	Input Under-Voltage Lockout	Rising			4.0	V
		Hysteresis		0.3		
I _Q	Supply Current	No Load		150	300	μA
I _{SHDN}	Shutdown Current	V _{EN} = GND			1	μA
V _{OUT}	Output Voltage Range		0.6		0.94 V _{IN}	V
V _{OUT}	Output Voltage Accuracy	I _{OUT} = 0A to 3A	-2.5		2.5	%
ΔV _{LINREG} / ΔV _{IN}	Line Regulation	V _{IN} = 4.5V to 13.2V		0.023		%/V
ΔV _{LOADREG}	Load Regulation	V _{IN} = 12V, V _{OUT} = 5V, I _{OUT} = 0A to 3A		0.4		%
V _{FB}	Feedback Reference Voltage (adjustable version)	No Load, T _A = 25°C	0.59	0.60	0.61	V
I _{FBLEAK}	FB Leakage Current	V _{OUT} = 1.2V			0.2	μA
		Adjustable Version				
		Fixed Version		2		
F _{OSC}	Oscillator Frequency		0.6	0.8	1	MHz
T _S	Start-Up Time	I _{OUT} = 3A, V _{OUT} = 5V		2		ms
	Foldback Frequency			200		kHz
DC	Maximum Duty Cycle				94	%
T _{ON}	Minimum Turn-On Time			100		ns
T _{SS}	Soft-Start Time			2		ms
R _{DS(ON)H}	P-Channel On Resistance	V _{IN} = 12V		0.12		Ω
		V _{IN} = 6V		0.15		
η	Efficiency	V _{IN} = 12V, V _{OUT} = 5V, I _{OUT} = 3A		90		%
I _{LIM}	PMOS Current Limit		4.0	6.0		A
I _{LXLEAK}	LX Leakage Current	V _{IN} = 13.2V, V _{LX} = 0 to V _{IN}			1	μA
T _{SD}	Over-Temperature Shutdown Threshold			140		°C
T _{HYS}	Over-Temperature Shutdown Hysteresis			25		°C
V _{ILEN}	EN Logic Low Input Threshold				0.4	V
V _{IHEN}	EN Logic High Input Threshold		1.4			V
I _{EN}	EN Input Current	V _{EN} = 0V, V _{EN} = 13.2V	-1.0		1.0	μA

1. The AAT1161 is guaranteed to meet performance specifications over the -40°C to +85°C operating temperature range and is assured by design, characterization, and correlation with statistical process controls.

Typical Characteristics

Efficiency vs. Load Current
($V_{OUT} = 5V$)

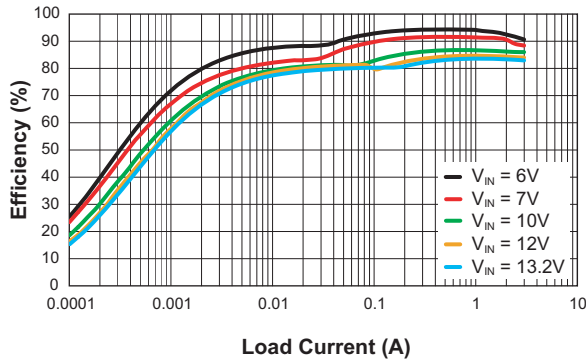

Efficiency vs. Load Current
($V_{OUT} = 3.3V$)

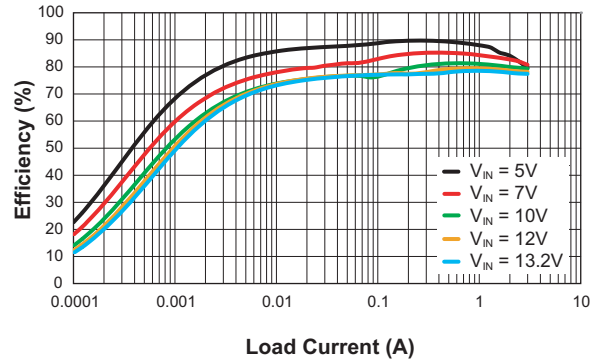

Load Regulation
($V_{OUT} = 5V$)

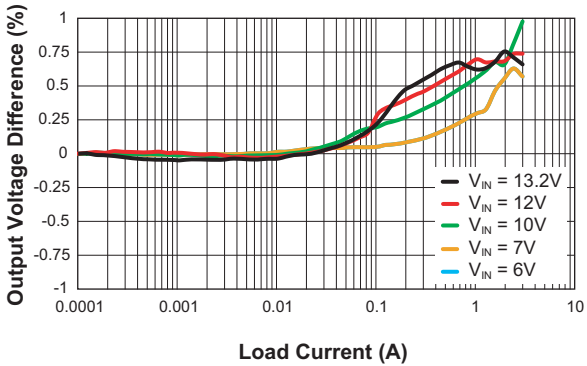

Load Regulation
($V_{OUT} = 3.3V$)

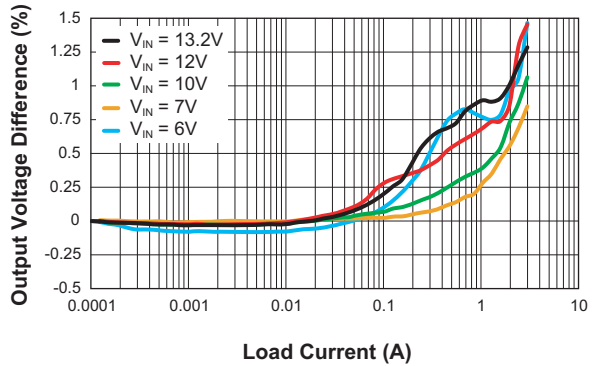

Line Regulation
($V_{OUT} = 5V$)

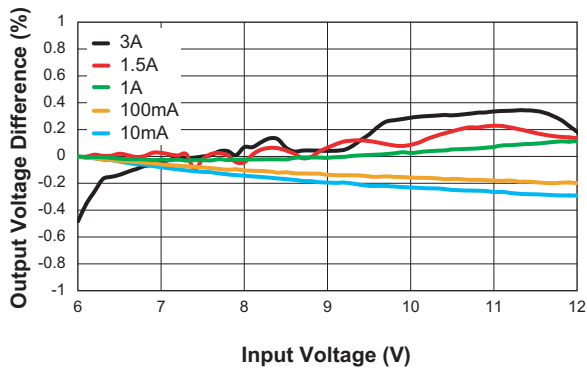

Line Regulation
($V_{OUT} = 3.3V$)

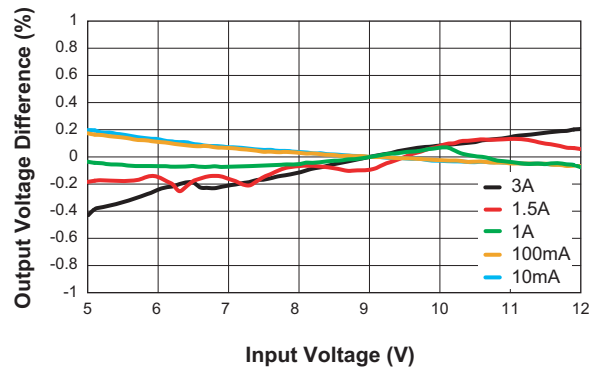

1.3.2V Input, 3A Step-Down Converter

Typical Characteristics

Non Switching Supply Current vs. Input Voltage

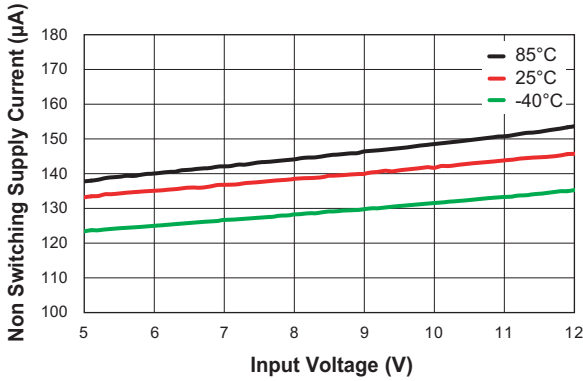

P-Channel $R_{DS(ON)}$ vs. Temperature ($V_{IN} = 6V$)

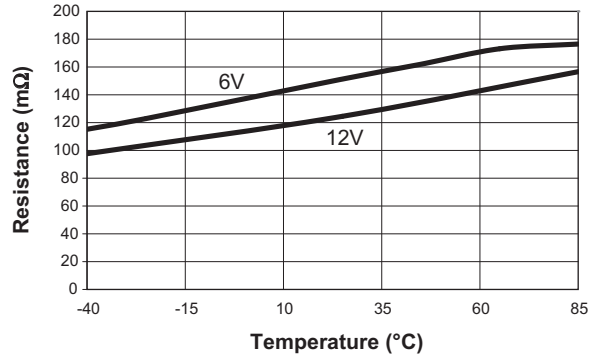

Switching Frequency vs. Temperature ($V_{IN} = 6V$)

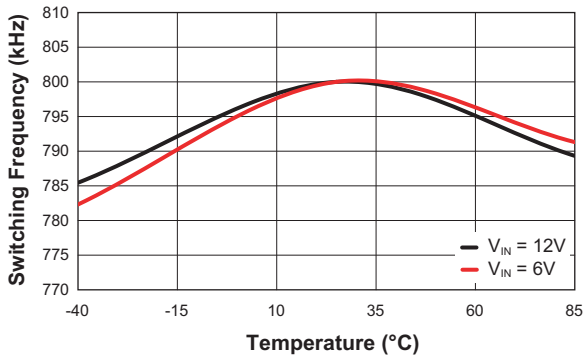

V_{OUT} Tolerance vs. Temperature ($V_{OUT} = 3.3V$; $I_{LOAD} = 3A$)

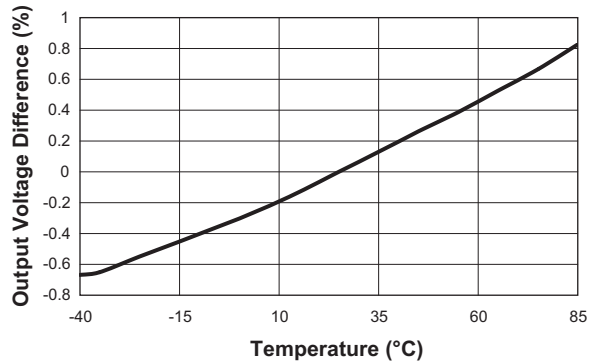

Line Transient

($V_{OUT} = 5.0V$; $C_{FF} = 100pF$; $V_{IN} = 6V$ to $11V$;
 $I_{OUT} = 3A$; $C_{IN} = 10\mu F$; $C_{OUT} = 66\mu F$; $L = 3.8\mu H$)

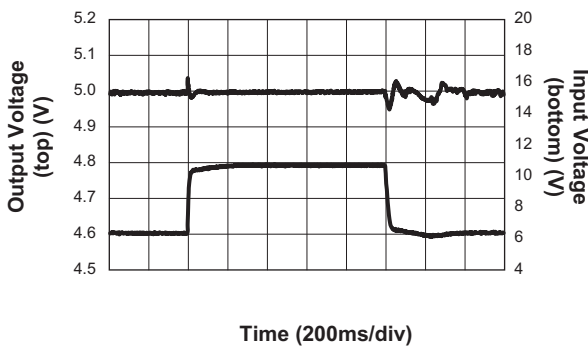

Load Transient

($V_{OUT} = 5.0V$; $C_{FF} = 100pF$; $I_{OUT} = 1A$ to $3A$; $C_{OUT} = 66\mu F$)

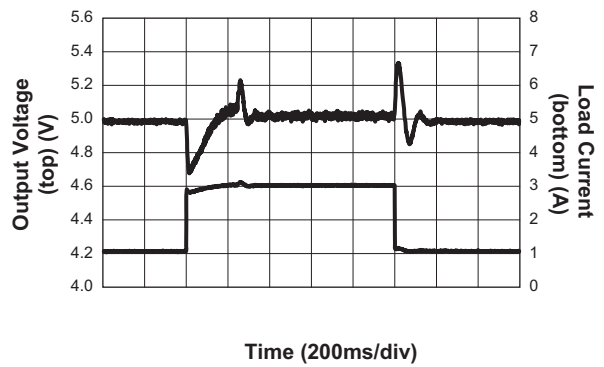

Typical Characteristics

Load Transient

($V_{OUT} = 5.0V$; $C_{FF} = 100pF$; $I_{OUT} = 50mA$ to $3A$; $C_{OUT} = 66\mu F$)

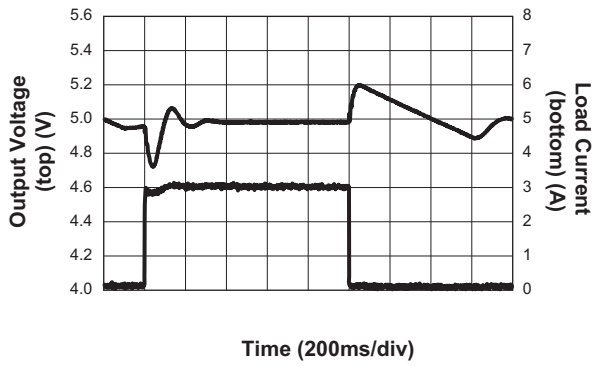

Start-Up Time

($V_{OUT} = 5.0V$; $C_{FF} = 100pF$; $R_{LOAD} = 1.67\Omega$; $C_{IN} = 10\mu F$; $C_{OUT} = 22\mu F$; $L = 3.8\mu H$)

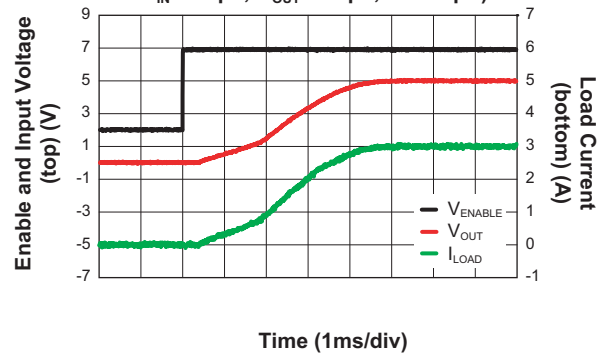

Functional Block Diagram

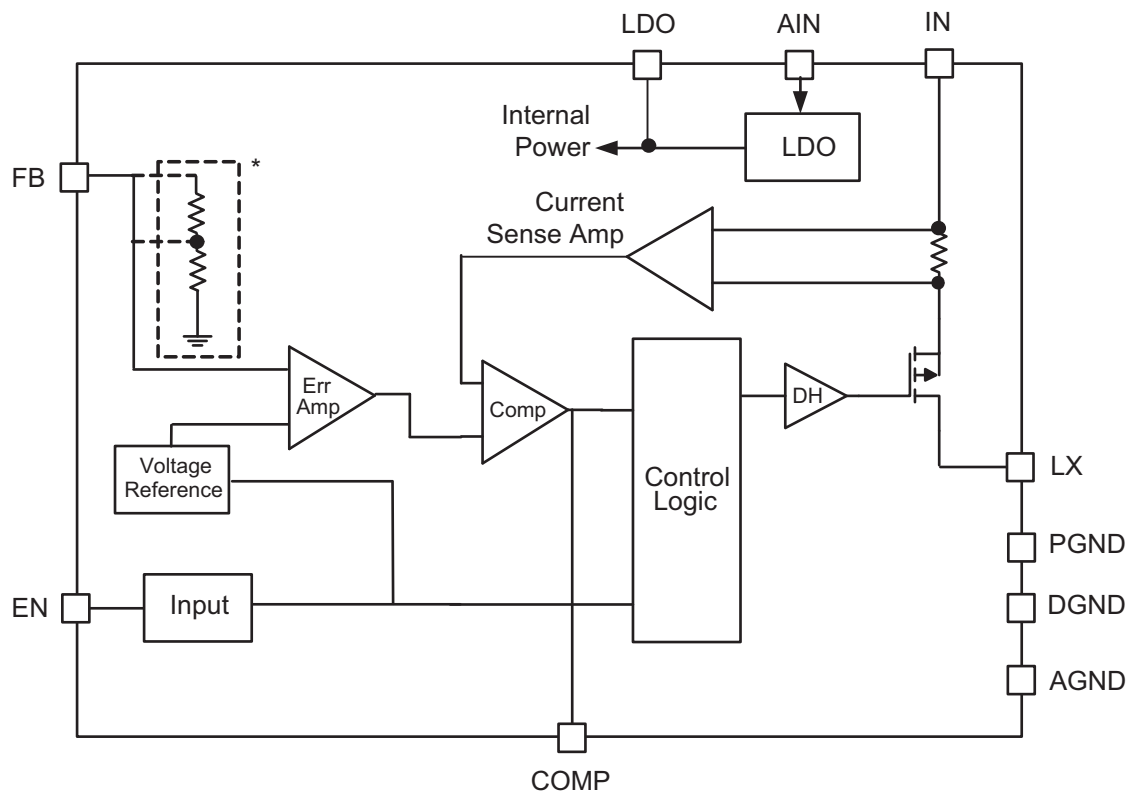

* For fixed output voltage versions, FB is connected to the error amplifier through the resistive voltage divider shown.

Functional Description

The AAT1161 is a current-mode step-down DC/DC converter that operates over a wide 4V to 13.2V input voltage range and is capable of supplying up to 3A to the load with the output voltage regulated as low as 0.6V. The P-channel power switch is internal, reducing the number of external components required. An external Schottky diode is used for the low side rectifier. The output voltage is adjusted by an external resistor divider; fixed output voltage versions are available upon request. The regulation system is externally compensated, allowing the circuit to be optimized for each application. The AAT1161 includes cycle-by-cycle current limiting, frequency fold-back for improved short-circuit performance, and thermal overload protection to prevent damage in the event of an external fault condition.

Control Loop

The AAT1161 regulates the output voltage using constant frequency current mode control. The AAT1161 monitors current through the high-side P-channel MOSFET and uses that signal to regulate the output voltage. This provides improved transient response and eases compensation. Internal slope compensation is included to ensure the current "inside loop" stability. High efficiency is maintained under light load conditions by automatically switching to variable frequency Light Load control. In this condition, transition losses are reduced by operating at a lower frequency at light loads. The AAT1161 uses an external Schottky rectifier diode to minimize cost.

1.3.2V Input, 3A Step-Down Converter

Low Dropout Operation

The AAT1161 operates with duty cycle up to 100% to minimize the dropout voltage, increasing the available input voltage range for a given output voltage. As the input voltage decreases toward the output voltage, the duty cycle increases until it reaches the maximum on-time. Further reduction of the supply voltage forces the PMOS on 100%; the output voltage is determined by the p-channel MOSFET switch and inductor voltage drops.

Short-Circuit Protection

The AAT1161 uses a cycle-by-cycle current limit to protect itself and the load from an external fault condition. When the inductor current reaches the internally set 6.0A current limit, the P-channel MOSFET switch turns off, limiting the inductor and the load current. During an overload condition, when the output voltage drops below 25% of the regulation voltage (0.15V at FB), the AAT1161 switching frequency drops by a factor of 4. This gives the inductor current ample time to reset during the off time to prevent the inductor current from rising uncontrolled in a short-circuit condition.

Thermal Protection

The AAT1161 includes thermal protection that disables the regulator when the die temperature reaches 140°C. It automatically restarts when the temperature decreases by 25°C or more.

Applications Information

Setting the Output Voltage

Figure 1 shows the basic application circuit for the AAT1161 and output setting resistors. Resistors R3 and R6 program the output to regulate at a voltage higher than 0.6V. To limit the bias current required for the external feedback resistor string while maintaining good noise immunity, the minimum suggested value for R6 is 5.9kΩ. Although a larger value will further reduce quiescent current, it will also increase the impedance of the feedback node, making it more sensitive to external noise and interference. Table 1 summarizes the resistor values for various output voltages with R6 set to either 5.9kΩ for good noise immunity or 59kΩ for reduced no load input current. The external resistors set the output voltage according to the following equation:

$$V_{OUT} = 0.6V \left(1 + \frac{R3}{R6} \right)$$

or

$$R3 = \left(\frac{V_{OUT}}{V_{REF}} - 1 \right) \cdot R6$$

The adjustable feedback resistors, combined with an external feed forward capacitor (C1 in Figure 1), deliver enhanced transient response for extreme pulsed load applications. The addition of the feed forward capacitor typically requires a larger output capacitor C3/C4/C5 for stability. Larger C3/C4/C5 values reduce overshoot and undershoot during startup and load changes. However, do not exceed 470pF to maintain stable operation.

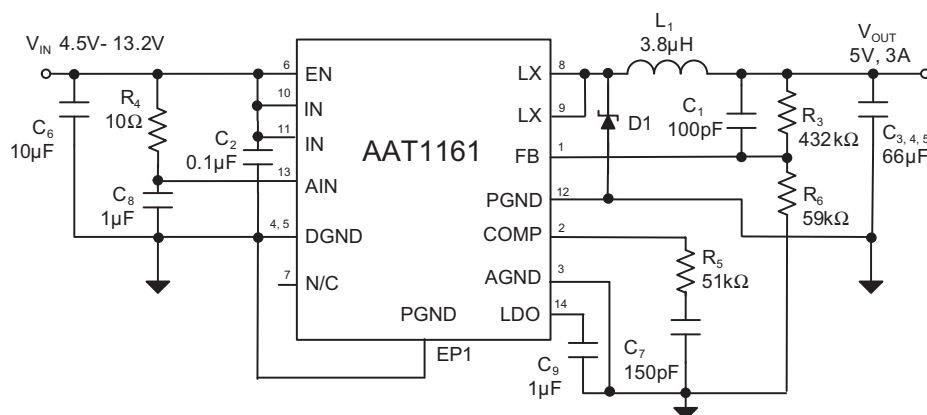

Figure 1: Typical Application Circuit.

13.2V Input, 3A Step-Down Converter

Table 1 shows the resistor selection for different output voltage settings.

V _{OUT} (V)	R6 = 5.9kΩ R3 (kΩ)	R6 = 59kΩ R3 (kΩ)
0.8	1.96	19.6
0.9	2.94	29.4
1.0	3.92	39.2
1.1	4.99	49.9
1.2	5.90	59.0
1.3	6.81	68.1
1.4	7.87	78.7
1.5	8.87	88.7
1.8	11.8	118
1.85	12.4	124
2.0	13.7	137
2.5	18.7	187
3.3	26.7	267
5.0	43.2	432

Table 1: Resistor Selection for Different Output Voltage Settings. Standard 1% Resistors are Substituted for Calculated Values.

Inductor Selection

For most designs, the AAT1161 operates with inductors of 2μH to 4.7μH. Low inductance values are physically smaller, but require faster switching, which results in some efficiency loss. The inductor value can be derived from the following equation:

$$L1 = \frac{V_{OUT} \cdot (V_{IN} - V_{OUT})}{V_{IN} \cdot \Delta I_L \cdot F_{OSC}}$$

Where ΔI_L is inductor ripple current. Large value inductors lower ripple current and small value inductors result in high ripple currents. Choose inductor ripple current approximately 32% of the maximum load current 3A, or $\Delta I_L = 959\text{mA}$. For output voltages above 3.3V, the mini-

imum recommended inductor is 3.8μH. For 3.3V and below, use a 2 to 2.2μH inductor. For optimum voltage-positioning load transients, choose an inductor with DC series resistance in the 15mΩ to 20mΩ range. For higher efficiency at heavy loads (above 1A), or minimal load regulation (but some transient overshoot), the resistance should be kept below 18mΩ. The DC current rating of the inductor should be at least equal to the maximum load current plus half the ripple current to prevent core saturation (3A + 526mA). Table 2 lists some typical surface mount inductors that meet target applications for the AAT1161.

Manufacturer's specifications list both the inductor DC current rating, which is a thermal limitation, and the peak current rating, which is determined by the saturation characteristics. The inductor should not show any appreciable saturation under normal load conditions. Some inductors may meet the peak and average current ratings yet result in excessive losses due to a high DCR. Always consider the losses associated with the DCR and its effect on the total converter efficiency when selecting an inductor. For example, the 3.7μH CDR7D43 series inductor selected from Sumida has an 18.9mΩ DCR and a 4.3ADC current rating. At full load, the inductor DC loss is 170mW which gives only a 1.13% loss in efficiency for a 3A, 5V output.

Input Capacitor Selection

The input capacitor reduces the surge current drawn from the input and switching noise from the device. The input capacitor impedance at the switching frequency shall be less than the input source impedance to prevent high frequency switching current passing to the input. A low ESR input capacitor sized for maximum RMS current must be used. Ceramic capacitors with X5R or X7R dielectrics are highly recommended because of their low ESR and small temperature coefficients. A 22μF ceramic capacitor is sufficient for most applications.

Manufacturer	Part Number	L (μH)	Max DCR (mΩ)	Rated DC Current (A)	Size WxLxH (mm)
Sumida	CDRH103RNP-2R2N	2.2	16.9	5.10	10.3x10.5x3.1
Sumida	CDR7D43MNNP-3R7NC	3.7	18.9	4.3	7.6x7.6x4.5
Coilcraft	MSS1038-382NL	3.8	13	4.25	10.2x7.7x3.8

Table 2: Typical Surface Mount Inductors.

13.2V Input, 3A Step-Down Converter

To estimate the required input capacitor size, determine the acceptable input ripple level (V_{PP}) and solve for C . The calculated value varies with input voltage and is a maximum when V_{IN} is double the output voltage.

$$C_{IN} = \frac{\frac{V_O}{V_{IN}} \cdot \left(1 - \frac{V_O}{V_{IN}}\right)}{\left(\frac{V_{PP}}{I_O} - ESR\right) \cdot F_{OSC}}$$

$$\frac{V_O}{V_{IN}} \cdot \left(1 - \frac{V_O}{V_{IN}}\right) = \frac{1}{4} \text{ for } V_{IN} = 2 \cdot V_O$$

$$C_{IN(MIN)} = \frac{1}{\left(\frac{V_{PP}}{I_O} - ESR\right) \cdot 4 \cdot F_{OSC}}$$

Always examine the ceramic capacitor DC voltage coefficient characteristics when selecting the proper value. For example, the capacitance of a 10 μ F, 16V, X5R ceramic capacitor with 12V DC applied is actually about 8.5 μ F.

The maximum input capacitor RMS current is:

$$I_{RMS} = I_O \cdot \sqrt{\frac{V_O}{V_{IN}} \cdot \left(1 - \frac{V_O}{V_{IN}}\right)}$$

The input capacitor RMS ripple current varies with the input and output voltage and will always be less than or equal to half of the total DC load current:

$$\sqrt{\frac{V_O}{V_{IN}} \cdot \left(1 - \frac{V_O}{V_{IN}}\right)} = \sqrt{D \cdot (1 - D)} = \sqrt{0.5^2} = \frac{1}{2}$$

for $V_{IN} = 2 \cdot V_O$

$$I_{RMS(MAX)} = \frac{I_O}{2}$$

The term $\frac{V_O}{V_{IN}} \cdot \left(1 - \frac{V_O}{V_{IN}}\right)$ appears in both the input voltage ripple and input capacitor RMS current equations and is at maximum when V_O is twice V_{IN} . This is why the input voltage ripple and the input capacitor RMS current ripple are a maximum at 50% duty cycle. The input capacitor provides a low impedance loop for the edges of pulsed current drawn by the AAT1161. Low ESR/ESL X7R and X5R ceramic capacitors are ideal for this function. To minimize stray inductance, the capacitor should be placed as closely as possible to the IC. This keeps the high frequency content of the input current localized,

minimizing EMI and input voltage ripple. The proper placement of the input capacitor ($C6$) can be seen in the evaluation board layout in Figure 3. Additional noise filtering for proper operation is accomplished by adding a small 0.1 μ F capacitor on the IN pins ($C2$).

A laboratory test set-up typically consists of two long wires running from the bench power supply to the evaluation board input voltage pins. The inductance of these wires, along with the low-ESR ceramic input capacitor, can create a high Q network that may affect converter performance. This problem often becomes apparent in the form of excessive ringing in the output voltage during load transients. Errors in the loop phase and gain measurements can also result. Since the inductance of a short PCB trace feeding the input voltage is significantly lower than the power leads from the bench power supply, most applications do not exhibit this problem. In applications where the input power source lead inductance cannot be reduced to a level that does not affect the converter performance, a high ESR tantalum or aluminum electrolytic should be placed in parallel with the low ESR, ESL bypass ceramic. This dampens the high Q network and stabilizes the system.

Output Capacitor Selection

The output capacitor is required to keep the output voltage ripple small and to ensure regulation loop stability. The output capacitor must have low impedance at the switching frequency. Ceramic capacitors with X5R or X7R dielectrics are recommended due to their low ESR and high ripple current. The output ripple V_{OUT} is determined by:

$$\Delta V_{OUT} \leq \frac{V_{OUT} \cdot (V_{IN} - V_{OUT})}{V_{IN} \cdot F_{OSC} \cdot L} \cdot \left(ESR + \frac{1}{8 \cdot F_{OSC} \cdot C_{OUT}} \right)$$

The output capacitor limits the output ripple and provides holdup during large load transitions. A 10 μ F to 47 μ F X5R or X7R ceramic capacitor typically provides sufficient bulk capacitance to stabilize the output during large load transitions and has the ESR and ESL characteristics necessary for low output ripple. The output voltage droop due to a load transient is dominated by the capacitance of the ceramic output capacitor. During a step increase in load current, the ceramic output capacitor alone supplies the load current until the loop responds. Within two or three switching cycles, the loop responds and the inductor current increases to match the load current demand. The relationship of the output

13.2V Input, 3A Step-Down Converter

voltage droop during the three switching cycles to the output capacitance can be estimated by:

$$C_{OUT} = \frac{3 \cdot \Delta I_{LOAD}}{V_{DROOP} \cdot F_{OSC}}$$

Once the average inductor current increases to the DC load level, the output voltage recovers. The above equation establishes a limit on the minimum value for the output capacitor with respect to load transients. The internal voltage loop compensation also limits the minimum output capacitor value to 22µF. This is due to its effect on the loop crossover frequency (bandwidth), phase margin, and gain margin. Increased output capacitance will reduce the crossover frequency with greater phase margin.

The maximum output capacitor RMS ripple current is given by:

$$I_{RMS(MAX)} = \frac{1}{2 \cdot \sqrt{3}} \cdot \frac{V_{OUT} \cdot (V_{IN(MAX)} - V_{OUT})}{L \cdot F_{OSC} \cdot V_{IN(MAX)}}$$

Dissipation due to the RMS current in the ceramic output capacitor ESR is typically minimal, resulting in less than a few degrees rise in hot-spot temperature.

Compensation

The AAT1161 step-down converter uses peak current mode control with slope compensation scheme to maintain stability with lower value inductors for duty cycles greater than 50%. The regulation feedback loop in the IC is stabilized by the components connected to the COMP pin, as shown in Figure 1.

To optimize the compensation components, the following equations can be used. The compensation resistor R_{COMP} (R5) is calculated using the following equation:

$$R_{COMP} (R5) = \frac{2\pi V_{OUT} \cdot C_{OUT} \cdot F_{OSC}}{10G_{EA} \cdot G_{COMP} \cdot V_{FB}}$$

Where $V_{FB} = 0.6V$, $G_{COMP} = 40.1734$ and $G_{EA} = 9.091 \cdot 10^{-5}$.

F_{OSC} is the switching frequency and C_{OUT} is based on the output capacitor calculation. The C_{COMP} value can be determined from the following equation:

$$C_{COMP} (C) = \frac{4}{2\pi R_{COMP} (R5) \cdot \left(\frac{F_{OSC}}{10}\right)}$$

Schottky Diode Selection

Power dissipation is the limiting factor when choosing a diode. The worst-case average power can be calculated as follows:

$$P_{DIODE} = \left(1 - \frac{V_{OUT}}{V_{IN}}\right) \cdot I_{OUT} \cdot V_F$$

where V_F is the voltage drop across the diode at the given output current I_{OUTMAX} . The total power dissipation of the diode is the combined total of forward power dissipation, reverse power dissipation and switching loss. Ensure that the selected diode will be able to dissipate the power based on the equation:

$$T_{J(MAX)} = T_{AMB} + \theta_{JA} \cdot P_{DIODE}$$

Where:

θ_{JA} = Package Thermal Resistance (°C/W)

$T_{J(MAX)}$ = Maximum Device Junction Temperature (°C)

T_A = Ambient Temperature (°C)

For reliable operation over the input voltage range, ensure that the reverse-repetitive maximum voltage is greater than the maximum input voltage ($V_{RRM} > V_{INMAX}$). The diode's forward-current specification must meet or exceed the maximum output current ($I_{F(AV)} \geq I_{OUTMAX}$). See Table 3 for recommended diodes for different I_{OUT} conditions.

13.2V Input, 3A Step-Down Converter

Part Number	V _F	I _{F(AV)}	V _{RRM}	θ _{JA}	T _{J(MAX)}	Manufacturer	Dimensions (mm)
M1FM3	0.46V	3A	30V	80°C/W	150°C	Shindengen	2.8x1.8
D1FH3	0.36V	3A	30V	65°C/W	125°C	Shindengen	4.4x2.5
SK32	0.5V	3A	20V	60°C/W	150°C	MCC	7x6
SS5820	0.475A	3A	20V	55°C/W	125°C	Jinan Jingheng	4.3x3.6
30BQ040/LSM345	0.43	3A	40V	46°C/W	150°C	IR/Microsemi	7x6
B220/A	0.5V	2A	20V	25°C/W	150°C	Diodes Inc.	4.3x3.6
SDM100K30L	0.485V	1A	30V	426°C/W	125°C	Diodes Inc.	1.7x1.3
B0520WS	0.43V	0.5A	20V	426°C/W	125°C	Diodes Inc.	1.7x1.3

Table 3: Recommended Schottky Diodes for Different Output Current Requirements.

Layout Guidance

Figure 2 is the schematic for the evaluation board. When laying out the PC board, the following layout guideline should be followed to ensure proper operation of the AAT1161:

- Exposed pad EP1 must be reliably soldered to PGND/DGND/AGND. The exposed thermal pad should be connected to board ground plane and pins 6, 11, 13, and 16. The ground plane should include a large exposed copper pad under the package for thermal dissipation.
- The power traces, including GND traces, the LX traces and the VIN trace should be kept short, direct and wide to allow large current flow. The L1 connection to the LX pins should be as short as possible. Use several via pads when routing between layers.
- Exposed pad pin EP2 must be reliably soldered to the LX pins 1 and 2. The exposed thermal pad should be connected to the board LX connection and the inductor L1 and also pins 1 and 2. The LX plane should include a large exposed copper pad under the package for thermal dissipation.
- The input capacitors (C2 and C6) should be connected as close as possible to IN (Pins 4 and 5) and DGND (Pin 6) to get good power filtering.
- Keep the switching node LX away from the sensitive FB node.
- The feedback trace for the FB pin should be separate from any power trace and connected as closely as possible to the load point. Sensing along a high-current load trace will degrade DC load regulation. The feedback resistors should be placed as close as possible to the FB pin (Pin 9) to minimize the length of the high impedance feedback trace.
- The output capacitors C3, 4, and 5 and L1 should be connected as close as possible and there should not be any signal lines under the inductor.
- The resistance of the trace from the load return to the PGND (Pin 16) should be kept to a minimum. This will help to minimize any error in DC regulation due to differences in the potential of the internal signal ground and the power ground.

AAT1161

13.2V Input, 3A Step-Down Converter

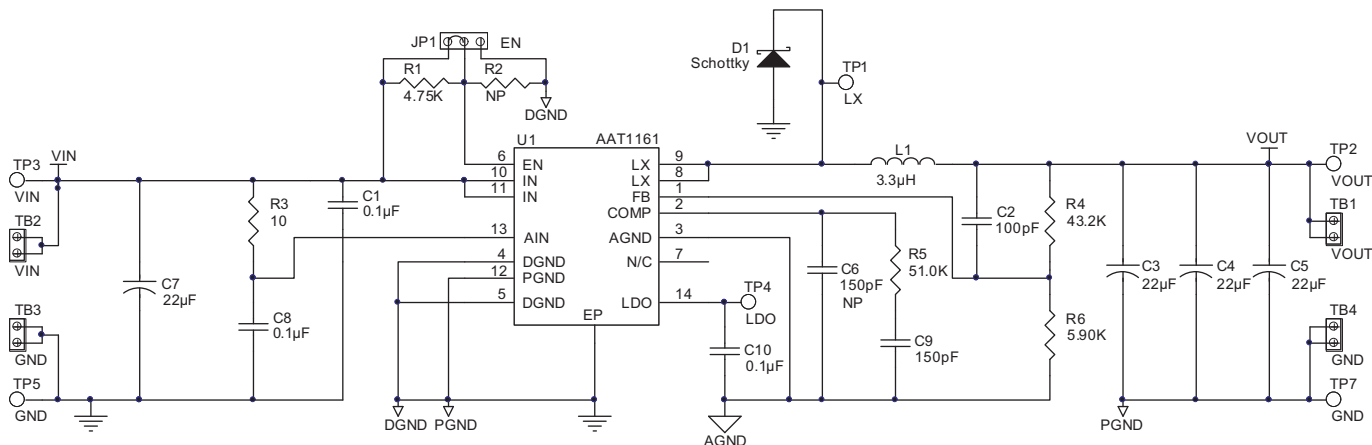

Note: Connect GND, DGND, PGND, and AGND at IC
 C2 - Increase C2 to reduce overshoot

Figure 2: AAT1161 Evaluation Board Schematic.

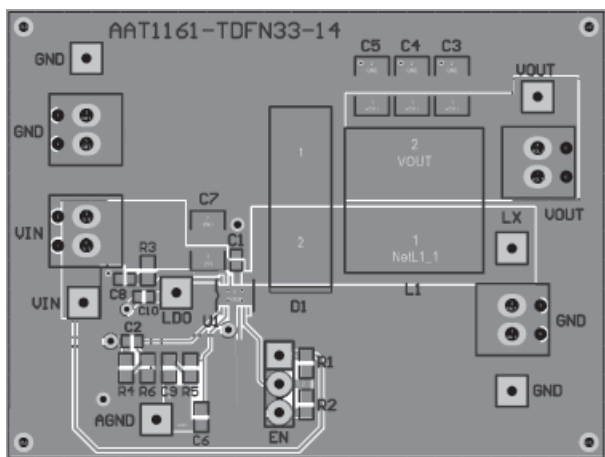

Figure 3: AAT1161 Evaluation Board Top Side Layout.

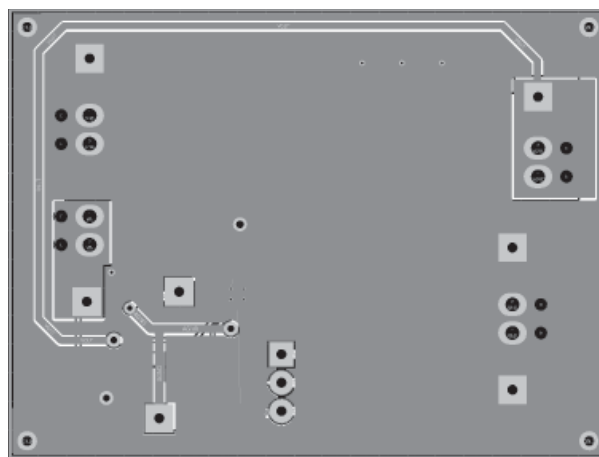

Figure 4: AAT1161 Evaluation Board Bottom Side Layout.

Design Example

Specifications

V_{OUT}	5V @ 3A, Pulsed Load $\Delta I_{LOAD} = 3A$
V_{IN}	12V nominal
F_{OSC}	800kHz
T_{AMB}	85°C in TDFN34-16 Package

Output Inductor

$$L_1 = \frac{V_{OUT} \cdot (V_{IN} - V_{OUT})}{V_{IN} \cdot \Delta I_L \cdot F_{OSC}} = 3.8\mu\text{H}; \text{ see Table 2.}$$

$$\Delta I_L = 0.32 \cdot I_{LOAD}$$

For Coilcraft inductor MSS1038 3.8 μ H DCR = 13m Ω max.

$$\Delta I_1 = \frac{V_{OUT}}{L_1 \cdot F_{OSC}} \cdot \left(1 - \frac{V_{OUT}}{V_{IN}}\right) = \frac{5V}{3.8\mu\text{H} \cdot 800\text{kHz}} \cdot \left(1 - \frac{5V}{12V}\right) = 959\text{mA}$$

$$I_{PK1} = I_{LOAD} + \frac{\Delta I_1}{2} = 3A + 0.479A = 3.48A$$

$$P_{L1} = I_{LOAD}^2 \cdot \text{DCR} = 3A^2 \cdot 13\text{m}\Omega = 117\text{mW}$$

Output Capacitor

$$V_{DROOP} = 0.2V$$

$$C_{OUT} = \frac{3 \cdot \Delta I_{LOAD}}{V_{DROOP} \cdot F_{OSC}} = \frac{3 \cdot 3A}{0.2V \cdot 800\text{kHz}} = 56\mu\text{F}; \text{ use three } 22\mu\text{F}$$

$$I_{RMS(MAX)} = \frac{1}{2 \cdot \sqrt{3}} \cdot \frac{(V_{OUT}) \cdot (V_{IN(MAX)} - V_{OUT})}{L \cdot F_{OSC} \cdot V_{IN(MAX)}} = \frac{1}{2 \cdot \sqrt{3}} \cdot \frac{5V \cdot (12V - 5V)}{3.8\mu\text{H} \cdot 800\text{kHz} \cdot 12V} = 277\text{mA}_{RMS}$$

$$P_{esr} = \text{esr} \cdot I_{RMS}^2 = 5\text{m}\Omega \cdot (277\text{mA})^2 = 384\mu\text{W}$$

13.2V Input, 3A Step-Down Converter**Input Capacitor**Input Ripple $V_{pp} = 50\text{mV}$

$$C_{IN} = \frac{1}{\left(\frac{V_{PP}}{I_{LOAD}} - ESR\right) \cdot 4 \cdot F_{OSC}} = \frac{1}{\left(\frac{50\text{mV}}{3\text{A}} - 5\text{m}\Omega\right) \cdot 4 \cdot 800\text{kHz}} = 26\mu\text{F}; \text{ use } 22\mu\text{F}$$

$$I_{RMS(MAX)} = \frac{I_{LOAD}}{2} = 1.5\text{Arms}$$

$$P = esr \cdot I_{RMS}^2 = 5\text{m}\Omega \cdot (1.5\text{A})^2 = 11.25\text{mW}$$

AAT1161 Losses

Total losses can be estimated by calculating at the nominal input voltage (12V). All values assume an 85°C ambient temperature and a 140°C junction temperature with the TDFN 50°C/W package.

$$R_{DS(ON)} = 0.18\Omega$$

$$t_{sw} = 5\text{ms}$$

$$I_Q = 300\mu\text{A}$$

$$P_{LOSS} = \frac{I_{LOAD}^2 \cdot (R_{DS(ON)} \cdot V_{OUT})}{V_{IN}} + [(t_{sw} \cdot F_{OSC} \cdot I_{LOAD} + I_Q) \cdot V_{IN}]$$

$$P_{LOSS} = 823\text{mW}$$

$$T_{J(MAX)} = T_{AMB} + \theta_{JA} \cdot P_{LOSS} = 85^\circ\text{C} + (50^\circ\text{C/W}) \cdot 0.823\text{W} = 126^\circ\text{C}$$

13.2V Input, 3A Step-Down Converter

Ordering Information

Package	Marking ¹	Part Number (Tape and Reel) ²
TDFN33-14	1HXYY	AAT1161IWO-0.6-T1



Skyworks Green™ products are compliant with all applicable legislation and are halogen-free.



For additional information, refer to *Skyworks Definition of Green™*, document number SQ04-0074.

Package Information

TDFN33-14³

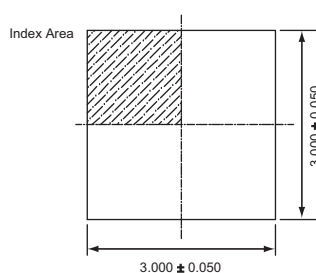

Top View

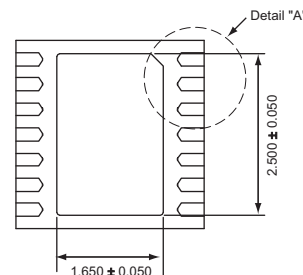

Bottom View

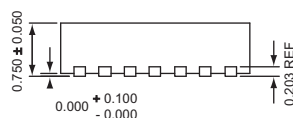

Side View

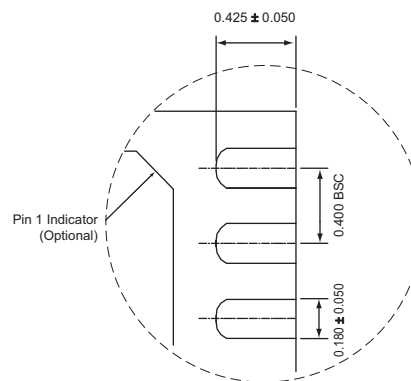

Detail "A"

All dimensions in millimeters.

1. XYY = assembly and date code.
 2. Sample stock is generally held on part numbers listed in **BOLD**.
 3. The leadless package family, which includes QFN, TQFN, DFN, TDFN and STDFN, has exposed copper (unplated) at the end of the lead terminals due to the manufacturing process. A solder fillet at the exposed copper edge cannot be guaranteed and is not required to ensure a proper bottom solder connection.

13.2V Input, 3A Step-Down Converter

Copyright © 2012 Skyworks Solutions, Inc. All Rights Reserved.

Information in this document is provided in connection with Skyworks Solutions, Inc. ("Skyworks") products or services. These materials, including the information contained herein, are provided by Skyworks as a service to its customers and may be used for informational purposes only by the customer. Skyworks assumes no responsibility for errors or omissions in these materials or the information contained herein. Skyworks may change its documentation, products, services, specifications or product descriptions at any time, without notice. Skyworks makes no commitment to update the materials or information and shall have no responsibility whatsoever for conflicts, incompatibilities, or other difficulties arising from any future changes.

No license, whether express, implied, by estoppel or otherwise, is granted to any intellectual property rights by this document. Skyworks assumes no liability for any materials, products or information provided hereunder, including the sale, distribution, reproduction or use of Skyworks products, information or materials, except as may be provided in Skyworks Terms and Conditions of Sale.

THE MATERIALS, PRODUCTS AND INFORMATION ARE PROVIDED "AS IS" WITHOUT WARRANTY OF ANY KIND, WHETHER EXPRESS, IMPLIED, STATUTORY, OR OTHERWISE, INCLUDING FITNESS FOR A PARTICULAR PURPOSE OR USE, MERCHANTABILITY, PERFORMANCE, QUALITY OR NON-INFRINGEMENT OF ANY INTELLECTUAL PROPERTY RIGHT; ALL SUCH WARRANTIES ARE HEREBY EXPRESSLY DISCLAIMED. SKYWORKS DOES NOT WARRANT THE ACCURACY OR COMPLETENESS OF THE INFORMATION, TEXT, GRAPHICS OR OTHER ITEMS CONTAINED WITHIN THESE MATERIALS. SKYWORKS SHALL NOT BE LIABLE FOR ANY DAMAGES, INCLUDING BUT NOT LIMITED TO ANY SPECIAL, INDIRECT, INCIDENTAL, STATUTORY, OR CONSEQUENTIAL DAMAGES, INCLUDING WITHOUT LIMITATION, LOST REVENUES OR LOST PROFITS THAT MAY RESULT FROM THE USE OF THE MATERIALS OR INFORMATION, WHETHER OR NOT THE RECIPIENT OF MATERIALS HAS BEEN ADVISED OF THE POSSIBILITY OF SUCH DAMAGE.

Skyworks products are not intended for use in medical, lifesaving or life-sustaining applications, or other equipment in which the failure of the Skyworks products could lead to personal injury, death, physical or environmental damage. Skyworks customers using or selling Skyworks products for use in such applications do so at their own risk and agree to fully indemnify Skyworks for any damages resulting from such improper use or sale.

Customers are responsible for their products and applications using Skyworks products, which may deviate from published specifications as a result of design defects, errors, or operation of products outside of published parameters or design specifications. Customers should include design and operating safeguards to minimize these and other risks. Skyworks assumes no liability for applications assistance, customer product design, or damage to any equipment resulting from the use of Skyworks products outside of stated published specifications or parameters.

Skyworks, the Skyworks symbol, and "Breakthrough Simplicity" are trademarks or registered trademarks of Skyworks Solutions, Inc., in the United States and other countries. Third-party brands and names are for identification purposes only, and are the property of their respective owners. Additional information, including relevant terms and conditions, posted at www.skyworksinc.com, are incorporated by reference.